



CLUTCH-BRAKES SERIES 5.5 and 5.6

Series 5.5 corresponds to clutch-brakes with double disc in the clutch side, in order to get a lower inertia. Their external covers and hubs are made of electro-welded steel.

Series 5.6 is similar to 5.5 but has double disc in both sides, improving the torque-inertia rate.

FRENO-EMBRAGUES SERIES 5.5 y 5.6

La serie 5.5 corresponde a las ejecuciones de freno-embrague con doble disco en el lado del embrague, con objeto de conseguir una menor inercia. Sus tapas exteriores y moyús están fabricados en acero electrosoldado.

La serie 5.6 es similar a la 5.5, pero se diferencia en que lleva doble disco tanto en el lado del embrague como en el del freno con lo que la relación par-inercia mejora.

Series 5.5

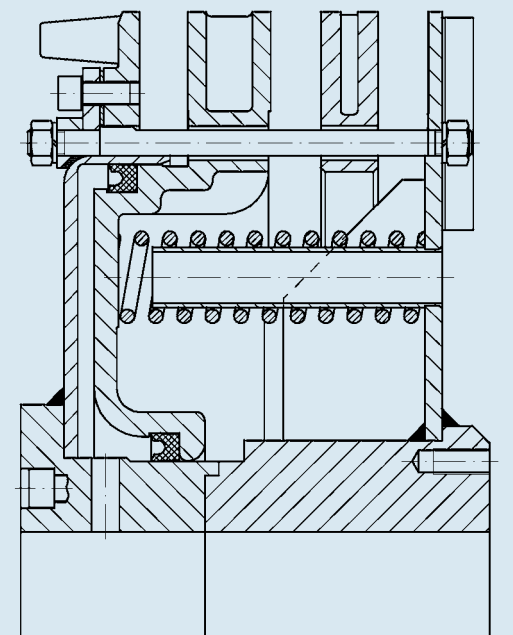

Series 5.6

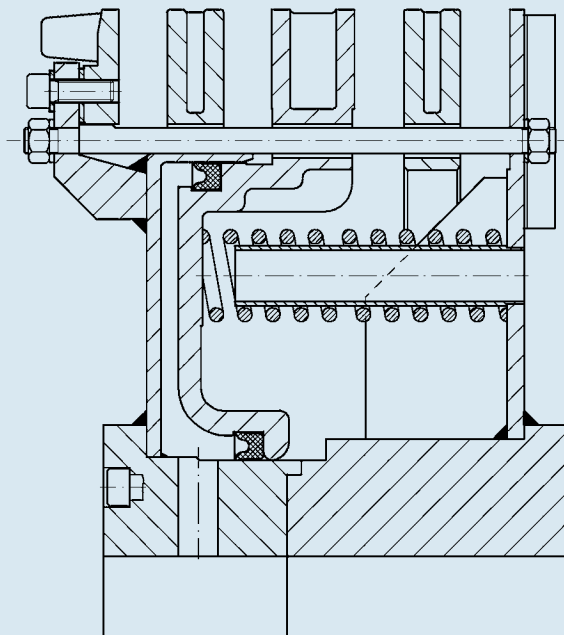



Series 5.51.*.WD

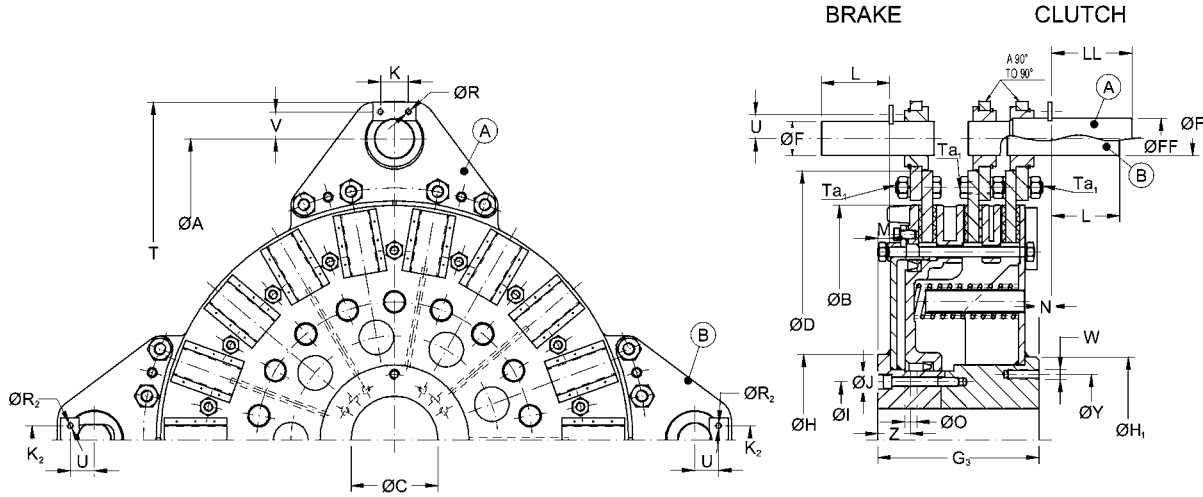

Series 5.54.*.WD

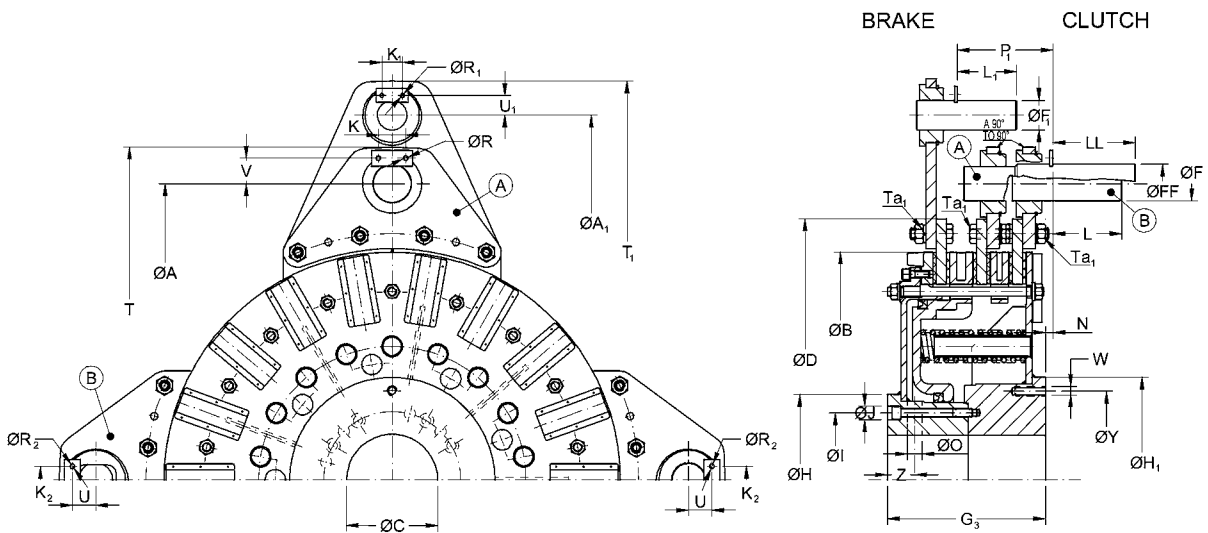



Series 5.51. __.WD / 5.54. __.WD

Size		18	36	55	75	76	77	78	79	81
Clutch torque	Nm	4200	9000	14000	20400	28600	38400	61600	90200	138000
Brake torque		1370	2930	4250	5900	8700	11500	17700	27800	35500
Pressure	bar	5,5								
Max speed	min ⁻¹	1400	1100	950	850	750	700	550	400	350
Weight	Kg	66	112	158	211	313	424	722	1120	1680
J Int. Ext.	Kg m ²	0,71	1,83	3,2	5,9	10,4	17,7	39	80	155
		0,637	1,775	3	4,745	10,1	16,27	36,36	65	150
New vol	dm ³	0,7	1,1	1,5	1,9	2,4	2,9	4,3	6	10,9
Max. wear Volum.		1,2	2,2	3	3,9	5,2	6,8	10,3	13	17,5
∅ A		495	610	695	770	880	970	1140	1300	1465
∅ A ₁		635	790	885	990	1135	1235	1450	-	1855
∅ B		380	466	542	599	675	755	885	1000	1140
∅ CH7	Min	45	50	60	60	75	90	115	140	150
	Max	80	108	114	125	145	160	180	220	260
∅ D		435	535	620	680	775	865	1000	1145	1276
∅ F		30	40	40	45	55	55	65	75	90
∅ F ₁		22	30	30	40	45	45	55	-	75
∅ FF		40	50	50	55	65	65	75	85	100
G ₃		134	169	190	209	242	260	331	361	400
∅ H		140(145)*	160(190)*	180(206)*	190(225)*	225(265)*	240(276)*	300(330)*	376	428
∅ H ₁		140	160	180	190	225	240	300	376	428
∅ I		95	123	132	150	168	186	212	290	340
∅ J		13,5	13,5	17	17	18,5	22,5	28	32	40
K		35	35	35	45	45	45	45	60	60
K ₁		25	25	25	35	35	35	45	-	60
K ₂		25	35	35	35	45	45	45	60	60
L		60	80	80	90	110	110	130	150	180
L ₁		45	60	60	80	90	90	110	-	150
LL		80	100	100	110	130	130	160	180	210
M		4	6	7,5	12,5	14	14	20	57,5	57,5
N		15	15	15	17,5	20	20	20	16,5	19,5
∅ O		2 a 180°	12	14	16	16	20	20	28	32
P ₁		90	120	133	135	160	174	225	-	217,5
∅ R		6,5	6,5	6,5	8,5	8,5	8,5	8,5	10,5	10,5
∅ R ₁		5,5	5,5	5,5	6,5	6,5	6,5	8,5	-	10,5
∅ R ₂		5,5	6,5	6,5	6,5	8,5	8,5	8,5	-	10,5
T		560	695	780	870	1000	1090	1285	1460	1650
T ₁		680	855	950	1 075	1220	1335	1570	-	2015
U		20	27	27	29,5	38,5	38,5	43,5	51	60
U ₁		16	20	20	27	29,5	29,5	38,5	-	52,5
V		27	32	32	38,5	43,5	43,5	48,5	-	65
W		M8	M12	M12	M12	M16	M16	M18	-	24
∅ Y		110	132	155	165	185	210	250	-	340
Z		26	31	36,5	41	48	53	67	76	85
Ta ₁	Nm	54	95	148	230	230	450	450	780	1590



*The measurements between brackets are in the case of lateral air feeding

*El valor entre paréntesis es para casos de entrada lateral de aire



Series 5.61.*.WD

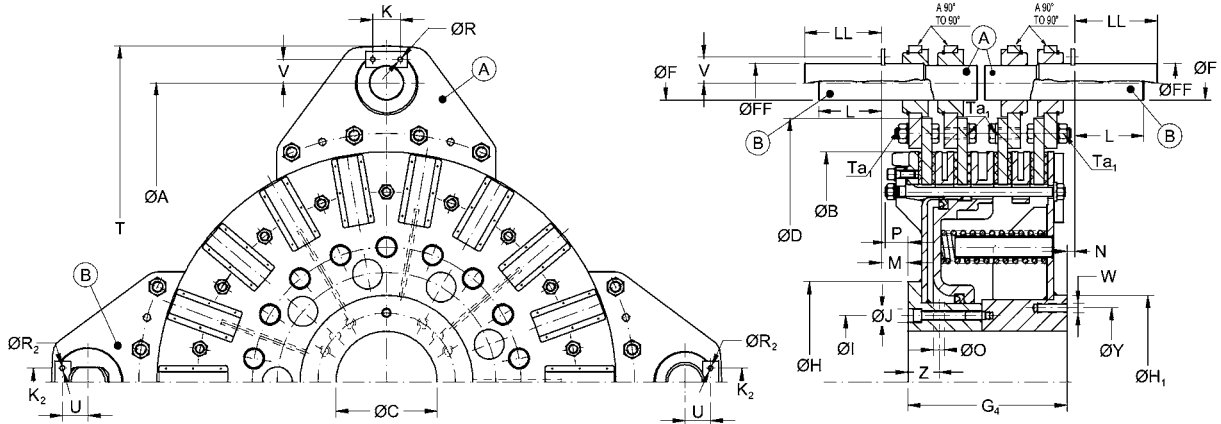

Series 5.64.*.WD

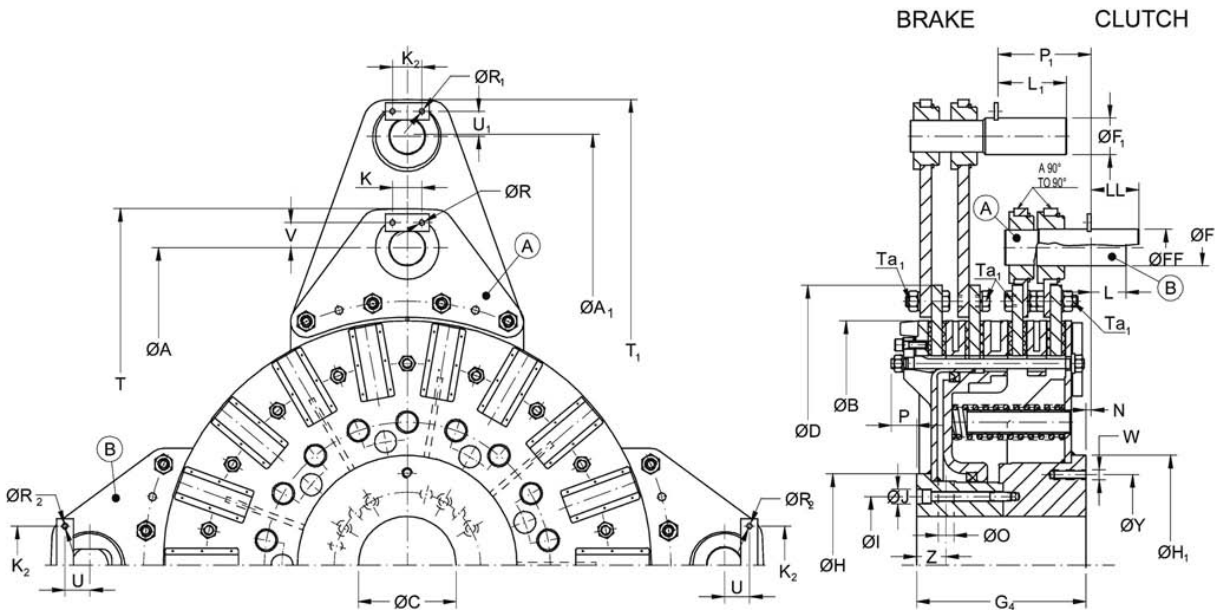

*Space to indicate the size / Espacio para indicar el tamaño



Series 5.61. __.WD / 5.64. __.WD

Size		18	36	55	75	76	77	78	79	81
Clutch torque	Nm	4200	9000	14000	20400	28600	38400	61600	90200	138000
Brake torque		2740	5860	8500	11800	17400	23000	35400	55600	71000
Pressure	bar	5,5								
Max speed	min ⁻¹	1400	1100	950	850	750	700	550	400	350
Weight	Kg	66	138	194	257	377	519	880	1340	1900
J Int.	Kg m ²	0,71	2,3	4	7,4	12,6	22,1	49	99	190
J Ext.		0,63	1,77	3	4,74	10,1	16,27	36,36	65	140
New vol		0,7	1,1	1,5	1,9	2,4	2,9	4,3	6	10,6
Max. wear Volum.		1,2	2,2	3	3,9	5,2	6,8	10,3	13	18,2
Ø A	dm ³	495	610	695	770	880	970	1140	1300	1465
Ø A ₁		635	790	885	990	1135	1235	1450	-	1855
Ø B		380	466	542	599	675	755	885	1000	1140
Ø CH7	Min	45	50	60	60	75	90	115	140	150
	Max	80	108	114	125	145	160	180	220	260
Ø D		435	535	620	680	775	865	1000	1145	1276
Ø F		30	40	40	45	55	55	65	75	90
Ø F ₁		20	50	50	55	65	65	75	-	75
Ø FF		40	50	50	55	65	65	75	85	100
G ₄		134	169	190	209	242	260	331	361	400
Ø H		140(145)*	160(190)*	180(206)*	190(225)*	225(265)*	240(276)*	300(330)*	376	428
Ø H ₁		140	160	180	190	225	240	300	376	428
Ø I		95	123	132	150	168	186	212	290	340
Ø J		13,5	13,5	17	17	18,5	22,5	28	32	40
K		35	35	35	45	45	45	45	60	60
K ₁		35	35	35	45	45	45	45	-	60
K ₂		25	35	35	35	45	45	45	60	60
L		60	80	80	90	110	110	130	150	180
L ₁		70	90	90	100	110	110	130	-	150
LL		80	100	100	110	130	130	160	180	210
M		33	38	38	38	48	48	58	-	30
N		15	15	15	17,5	20	20	20	16,5	19,5
Ø O	2 a 180°	12	14	16	16	20	20	28	32	35
P		28,5	39	36,5	35	42,5	47	56,5	-	50
P ₁		90	120	133	135	160	174	225	-	217,5
Ø R		6,5	6,5	6,5	8,5	8,5	8,5	8,5	10,5	10,5
Ø R ₁		5,5	6,5	6,5	8,5	8,5	8,5	8,5	-	10,5
Ø R ₂		5,5	6,5	6,5	6,5	8,5	8,5	8,5	-	10,5
T		560	695	780	870	1000	1090	1285	1460	1650
T ₁		680	875	970	1075	1220	1355	1600	-	2015
U		20	27	27	29,5	38,5	38,5	43,5	51	60
U ₁		27	32	32	38,5	43,5	43,5	48,5	-	52,5
V		27	32	32	38,5	43,5	43,5	48,5	-	65
W		M8	M12	M12	M12	M16	M16	M18	-	24
Ø Y		110	132	155	165	185	210	250	-	340
Z		26	31	36,5	41	48	53	67	76	85
Ta ₁	Nm	54	95	148	230	230	450	450	780	1590

*The measurements between brackets refer to clutch-brakes with lateral air feeding

*El valor entre paréntesis es para casos de entrada lateral de aire



ASSEMBLY EXAMPLES / EJEMPLOS DE MONTAJE

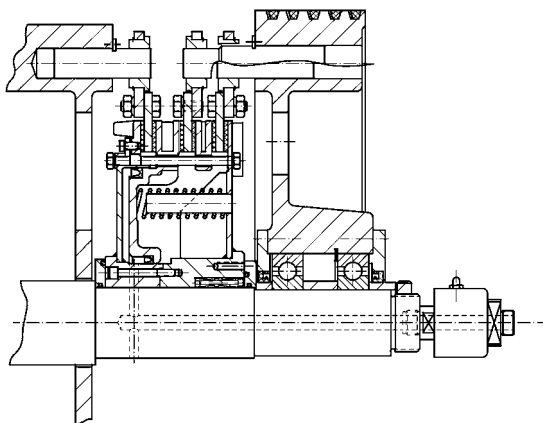

Series 5.51. __. WD

Mounting between frame and flywheel by means of 4 pins at 90° on the clutch side and 2 pins on the brake side all of them on the same diameter. Fixed in the shaft by locking ring.

Montaje entre bastidor y volante con 4 bulones a 90° en el lado embrague y 2 bulones en el lado freno situados todos ellos en el mismo diámetro. Montado en el eje con anillo de fijación.

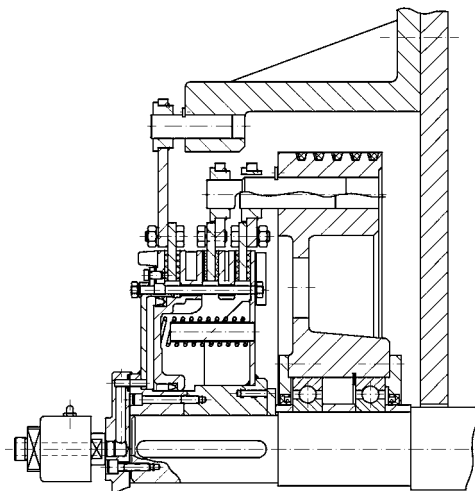

Series 5.54. __. AD

Mounting at shaft and by means of 4 pins at 90° on the clutch side and 2 pins on brake side on different diameters. Lateral air feeding.

Montaje en el extremo del eje con 4 bulones a 90° en el lado embrague y 2 bulones en el lado freno situados en diámetros distintos. Alimentación lateral de aire.

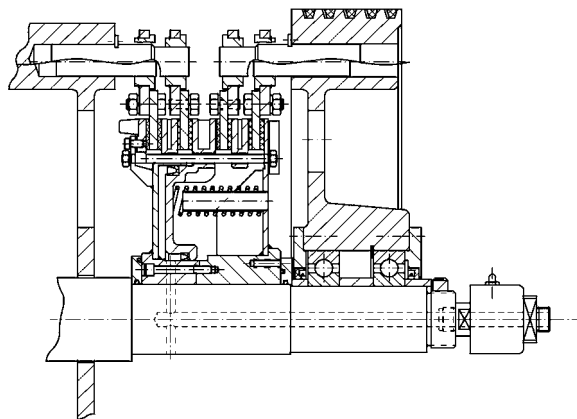

Series 5.61. __. WD

Mounting between frame and flywheel by means of 4 pins at 90° on the clutch side and 4 pins at 90° on the brake side, all of them on the same diameter.

Montaje entre bastidor y volante con 4 bulones a 90° en el lado embrague y 4 bulones a 90° en el lado freno, situados todos ellos en el mismo diámetro.

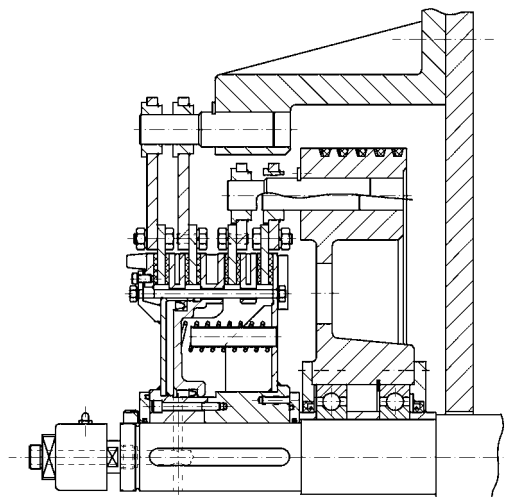

Series 5.64. __. WD

Mounting at shaft and by means of 4 pins at 90° on the clutch side and 2 pins connected to double discs on brake side, on different diameters.

Montaje en el extremo del eje con 4 bulones a 90° en el lado embrague y 2 bulones conectados a doble disco en el lado del freno, situados en diámetros distintos.